



15" Projective Capacitive 10pt touch screen

The ProLite T1532MSC 15" multi-touch screen is based on projected capacitive technology which thanks to a glass overlay covering the screen guarantees high durability, scratch-resistance and perfect picture performance. The touch function remains unaffected even if the glass is scratched. A solid and steady base supports the TouchScreen with an adjustable stand offering full 90 degree positioning angles. Menu Buttons are located on the side of the screen which can be locked to prevent tampering and includes a handy function to deactivate the TouchScreen for cleaning. In addition the edge-to-edge glass design creates an eye-catching finish with high light transmission guaranteeing perfect picture clarity and brilliant colours.



Touch technology - Capacitive

This technology uses a sensor-grid of micro-fine wires integrated into the glass that covers the screen. Touch is detected because electrical characteristics of the sensor grid change when human finger is placed on the glass. Thanks to the glass overlay this technology is highly durable, and the touch function remains unaffected even if the glass is scratched. It offers perfect picture performance and will work with human finger (also latex gloved) and stylus-pen.



ip54

The IP Code classifies how resistant a device is to foreign objects and moisture. IP54 means that the monitor will operate in dusty conditions, and will resist splashing water.

01 DISPLAY CHARACTERISTICS

Design	Edge to edge glass
Diagonal	15", 38cm
Panel	TN LED
Native resolution	1024 x 768 (0.8 megapixel)
Aspect ratio	4:3
Panel brightness	370 cd/m ²
Brightness	330 cd/m ² with touch
Light transmittance	90%
Static contrast	700:1 with touch
Response time (GTG)	8ms
Viewing zone	horizontal/vertical: 170°/160°, right/left: 85°/85°, up/down: 80°/80°
Colour support	16.7mln
Horizontal Sync	31,4 - 60kHz
Viewable area W x H	304 x 228mm, 12 x 9"
Pixel pitch	0.297mm
Bezel colour and finish	black, matte

02 TOUCH

Touch technology	projective capacitive
Touch points	10 (HID, only with supported OS)
Touch method	stylus, finger, glove (latex)
Touch interface	USB
Supported operating systems	All iiyama monitors are Plug & Play and compatible with Windows and Linux. For details regarding the supported OS for the touch models, please refer to the driver instruction file available in the downloads section.

03 INTERFACES / CONNECTORS / CONTROLS

Analog signal input	VGA x1
Digital signal input	DVI x1
Audio output	Speakers 2 x 1W

04 FEATURES

Water and dust protection	IP54 (front)
OSD key lock	yes

05 GENERAL

OSD languages	EN, DE, FR, ES, IT, CN, JP
Control buttons	Menu, Scroll up/ Brightness, Scroll down/ Mute, Select/ Auto, Power
User controls	contrast, brightness, auto adjust, H.position, V.position, H.size, phase, OSD H.position, OSD V.position, OSD timeout, reset, input select, OSD language, colour temperature, volume, mute
Convenience	Kensington-lock™ prepared
Plug&Play	DDC2B

06 MECHANICAL

Tilt angle 90° up; 5° down

VESA mounting 100 x 100mm

Cable management system yes

07 ACCESSORIES INCLUDED

Cables power, VGA, DVI, USB, Audio

Guides quick start guide, safety guide

Other Touch Panel Driver Disk (CD-ROM)

Cable cover yes

08 POWER MANAGEMENT

Power supply unit internal

Power supply AC 100 - 240V, 50/60Hz

Power usage 16W typical, 2W stand by, 2W off mode

09 SUSTAINABILITY

Regulations CB, CE, TÜV-Bauart, RoHS support, ErP, WEEE, CU, cULus, VCCI, REACH

REACH SVHC above 0.1%: Lead

10 DIMENSIONS / WEIGHT

Product dimensions W x H x D 351 x 306.5 x 202mm

Weight (without box) 4.5kg

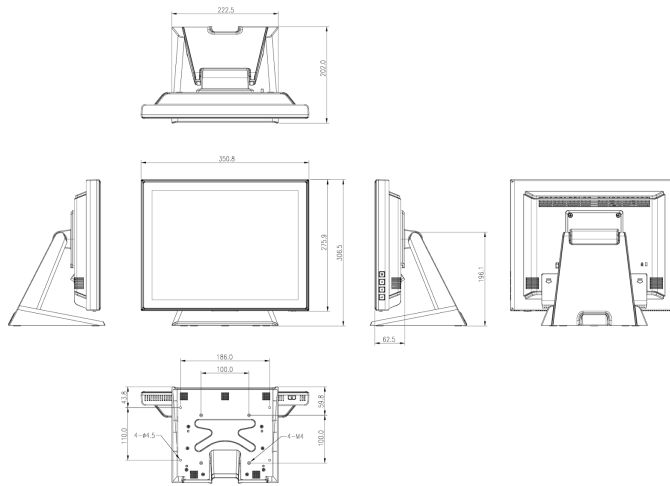

All trademarks and registered trademarks acknowledged. E & O E. Specification subject to change without notice. All LCD's comply with ISO-9241-307:2008 in connection with pixel defects.

© IYAMA CORPORATION. ALL RIGHTS RESERVED