

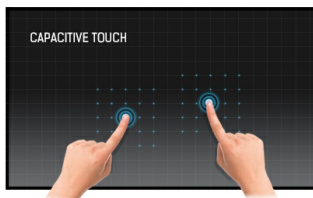

## 15.6" P-Cap 10 point multi-touch monitor with edge-to-edge glass

The 15.6" LED-backlit ProLite T1634MC-B5X uses Projective Capacitive Multi-Touch Technology, built into an eye catching bezel with edge-to-edge glass. The screen features a 1366 x 768 resolution, HDMI, DisplayPort and VGA inputs and a rugged bezel and IP54 rated front making it suitable for demanding environments. The ProLite T1634MC-B5X is the ideal solution for In-store Retail and Kiosk Integration.



### Touch technology - Capacitive

This technology uses a sensor-grid of micro-fine wires integrated into the glass that covers the screen. Touch is detected because electrical characteristics of the sensor grid change when human finger is placed on the glass. Thanks to the glass overlay this technology is highly durable, and the touch function remains unaffected even if the glass is scratched. It offers perfect picture performance and will work with human finger (also latex gloved) and stylus-pen.



### Scratch resistance

Scratch resistance is essential for touch solutions used in public places and schools. This is achieved thanks to a glass overlay covering the screen. It guarantees high durability of the touch function and even more importantly the touch function remains unaffected even if the glass is scratched.

## 01 DISPLAY CHARACTERISTICS

<b>Design</b>	Edge to edge glass
<b>Diagonal</b>	15.6", 39.5cm
<b>Panel</b>	TN LED
<b>Native resolution</b>	1366 x 768 (1.0 megapixel)
<b>Aspect ratio</b>	16:9
<b>Panel brightness</b>	400 cd/m <sup>2</sup>
<b>Brightness</b>	360 cd/m <sup>2</sup> with touch
<b>Light transmittance</b>	90%
<b>Static contrast</b>	500:1 with touch
<b>Response time (GTG)</b>	8ms
<b>Viewing zone</b>	horizontal/vertical: 170°/160°, right/left: 85°/85°, up/down: 80°/80°
<b>Colour support</b>	16.7mln
<b>Horizontal Sync</b>	31.4 - 60.3kHz
<b>Viewable area W x H</b>	344.2 x 193.5mm, 13.6 x 7.6"
<b>Pixel pitch</b>	0.252mm
<b>Bezel colour and finish</b>	black, matte

## 02 TOUCH

<b>Touch technology</b>	projective capacitive
<b>Touch points</b>	10 (HID, only with supported OS)
<b>Touch method</b>	stylus, finger, glove (latex)
<b>Touch interface</b>	USB
<b>Supported operating systems</b>	All iiyama monitors are Plug & Play and compatible with Windows and Linux. For details regarding the supported OS for the touch models, please refer to the driver instruction file available in the downloads section.

## 03 INTERFACES / CONNECTORS / CONTROLS

<b>Analog signal input</b>	VGA x1
<b>Digital signal input</b>	HDMI x1 DisplayPort x1
<b>HDCP</b>	yes

## 04 FEATURES

<b>Water and dust protection</b>	IP54 (front)
<b>OSD key lock</b>	yes

## 05 GENERAL

<b>OSD languages</b>	EN, DE, FR, ES, IT, CN, JP
<b>Control buttons</b>	Menu, Scroll up/ Brightness, Scroll down/ Contrast, Select, Power
<b>User controls</b>	contrast, brightness, power, OSD, auto adjust, H.position, V.position, H.size, fine, OSD H.position, OSD V.position, OSD timeout, reset, input select, OSD language, colour temperature
<b>Plug&amp;Play</b>	DDC2B

## 06 MECHANICAL

Tilt angle 90° up; 5° down

VESA mounting 100 x 100mm

Cable management system yes

## 07 ACCESSORIES INCLUDED

Cables power, USB, HDMI, DP

Guides quick start guide, safety guide

Other AC adapter, Touch Panel Driver Disk (CD-ROM)

Cable cover yes

## 08 POWER MANAGEMENT

Power supply unit external

Power supply DC 12 V

Power usage 16W typical, 2W stand by, 2W off mode

## 09 SUSTAINABILITY

Regulations CE, TÜV-Bauart, RoHS support, ErP, WEEE, CU, cULus, VCCI, REACH

REACH SVHC above 0.1%: Lead

## 10 DIMENSIONS / WEIGHT

Product dimensions W x H x D 381 x 285.5 x 202mm

Weight (without box) 4.4kg

EAN code 4948570116164

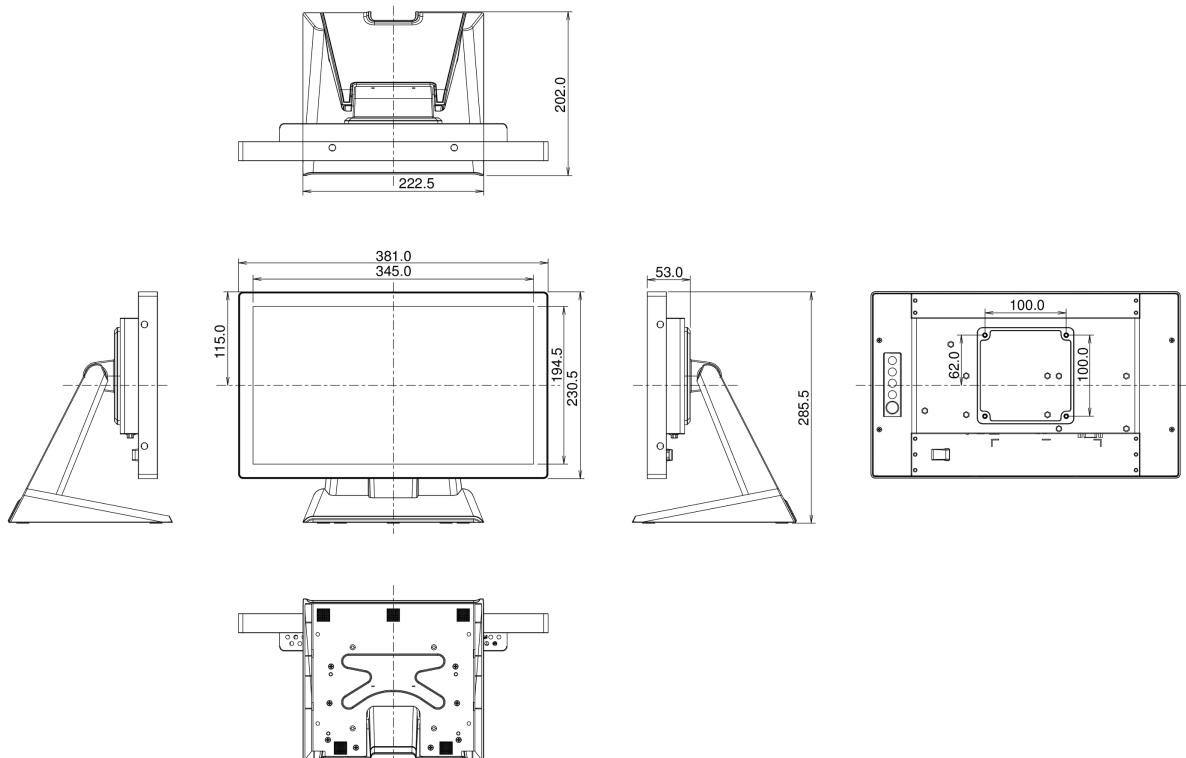

*All trademarks and registered trademarks acknowledged. E & O E. Specification subject to change without notice. All LCD's comply with ISO-9241-307:2008 in connection with pixel defects.*

© IYAMA CORPORATION. ALL RIGHTS RESERVED